

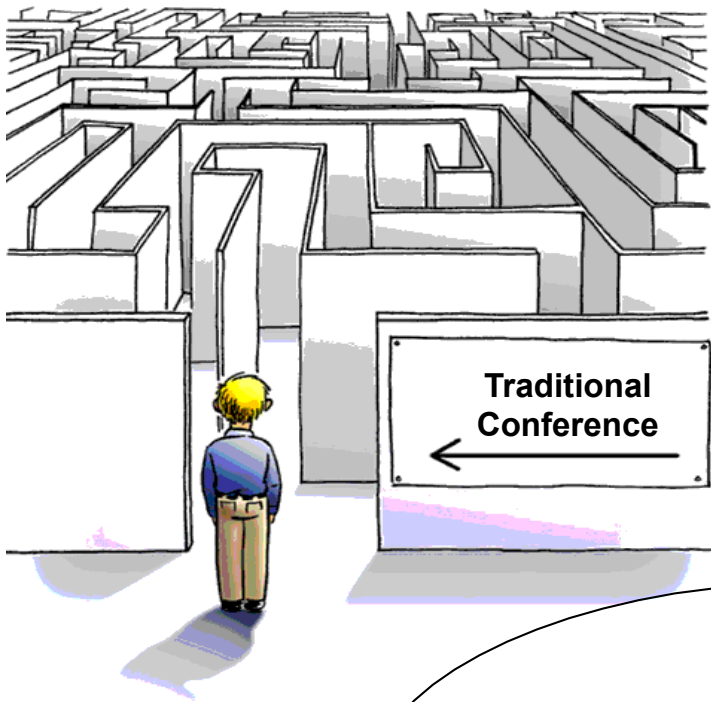

# Conference Impact





Most conferences are:

- Well organised
- Well presented
- Logistically smooth

But few consider:

- Content flow
- Group energy
- Level of interaction

We build ramps for delegates to **launch** from

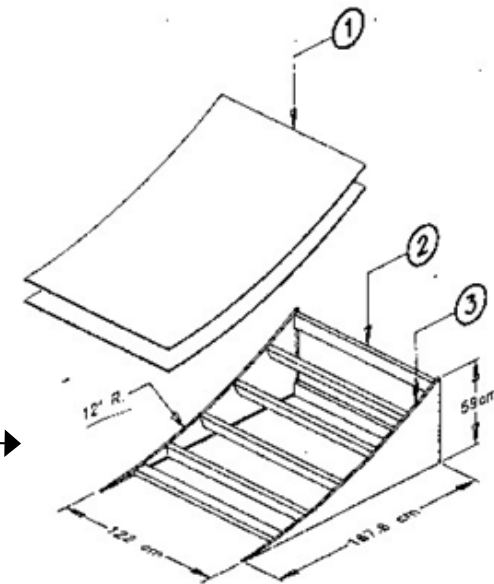

# The Difference

# Secret to Our Success

The magic in creating a great conference is in the **experience**...



...We achieve long-term impact by orchestrating delegate **engagement** and content flow.

*"Congratulations on one of the most successful conferences for planners I have seen in my 25 years in the business... Through your efforts, those of your conference team, and delegates themselves, the motivation will **last significantly longer** than 99% of other conferences I have seen"*

Noel Corley - Vice President; Retail Sales - Deutsche Asset Management



# The FAST Method

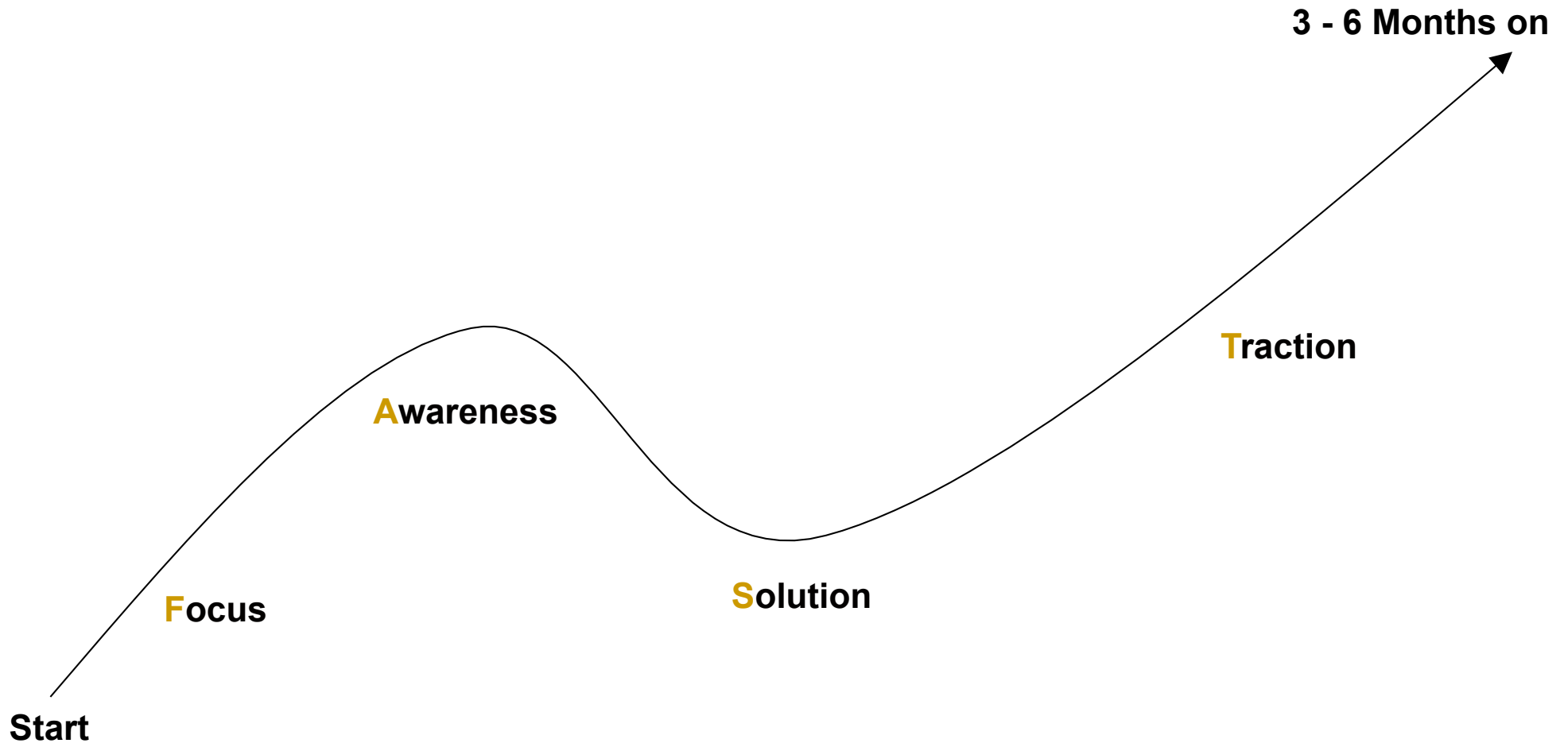

# Conference Outcomes

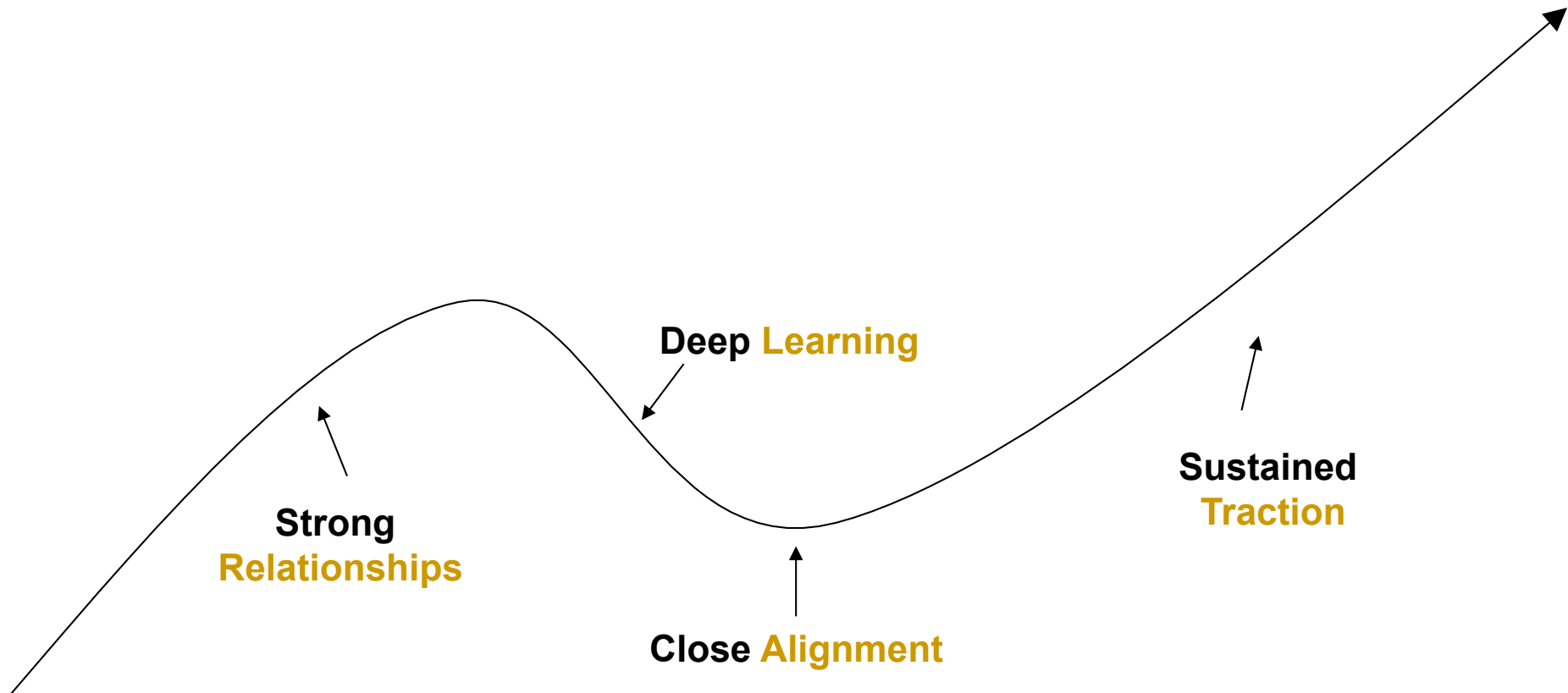

*“FAST Meeting Co. helped us design and facilitate an annual leaders forum... The feedback was unanimously positive, and delegates returned home feeling they had achieved something worthwhile, and their time had been well spent. An indirect benefit we gained has been the closer working relationship and more frequent communications which have since occurred between the State Associations, and this has had widespread benefits in many of the issues we share”*

**Andrew Mc Kinnon – Executive Director – Optometrists Association NSW**



# Our Process

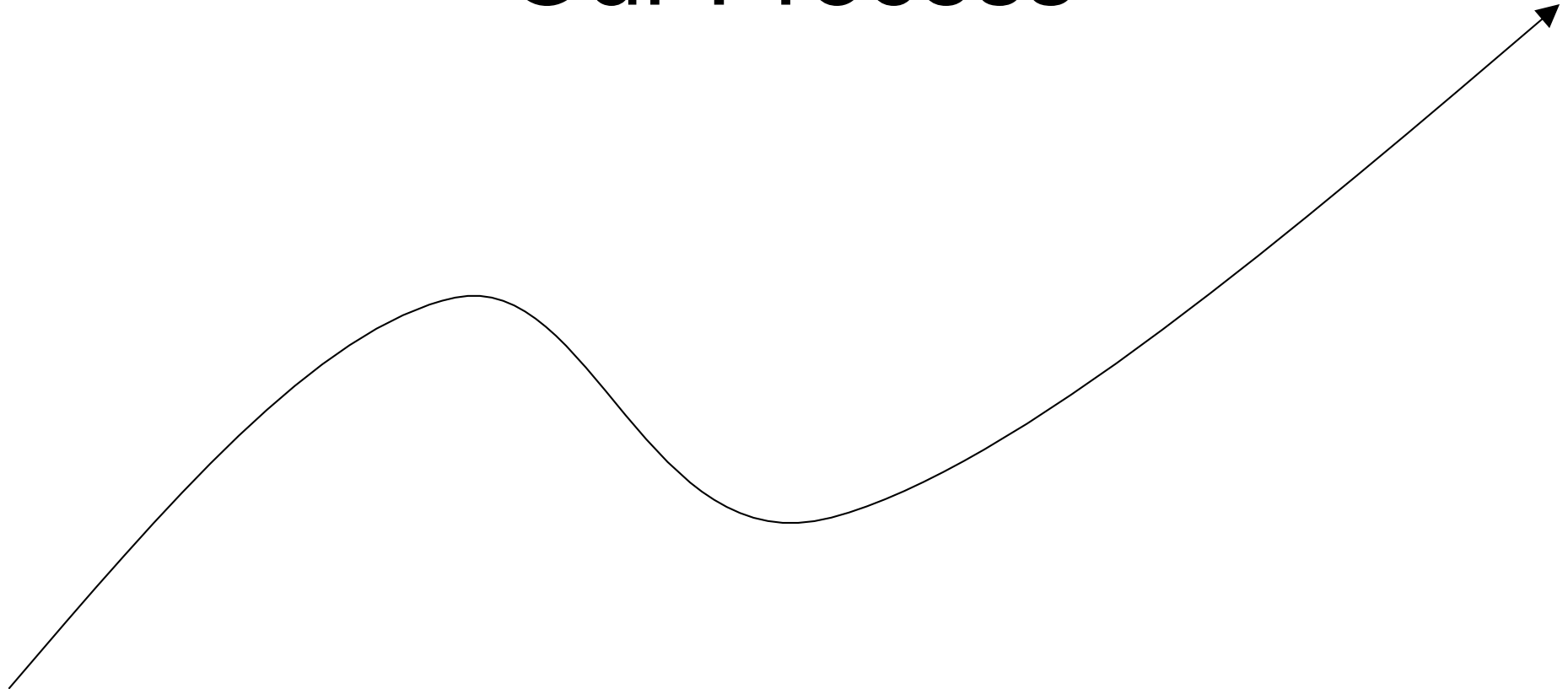

## Before:

We help you clarify what you want to **achieve**.

We use a 6 step Conference Design Road Map to create an innovative and engaging program

## During:

We help build relationships between participants through **innovative** workshop processes.

We support deeper learning through relevant, innovative **participatory** based conference methods

## After:

Delegates become **clear** about priority take outs.

We maximise the likelihood they will take **action**

# Our Services

1. Conference  
Design

2. Coach Client  
Facilitators and  
Presenters

3. Facilitate  
and MC

*“Thank you for your help. We are really pleased with the momentum we have generated from our conference. It was a big investment, however it is already paying off due to incredible follow through we are achieving. We have always been pretty good at doing what we say we will, however I have never seen this level of speed and structure with which our teams are implementing their project priorities. Our international Vice President told me that it was far and away **the most effective conference** he has ever been involved with in his career.”*

**Michael Lofaro – General Manager – Mainfreight**



# Our Services

# 1

Conference  
**Design**

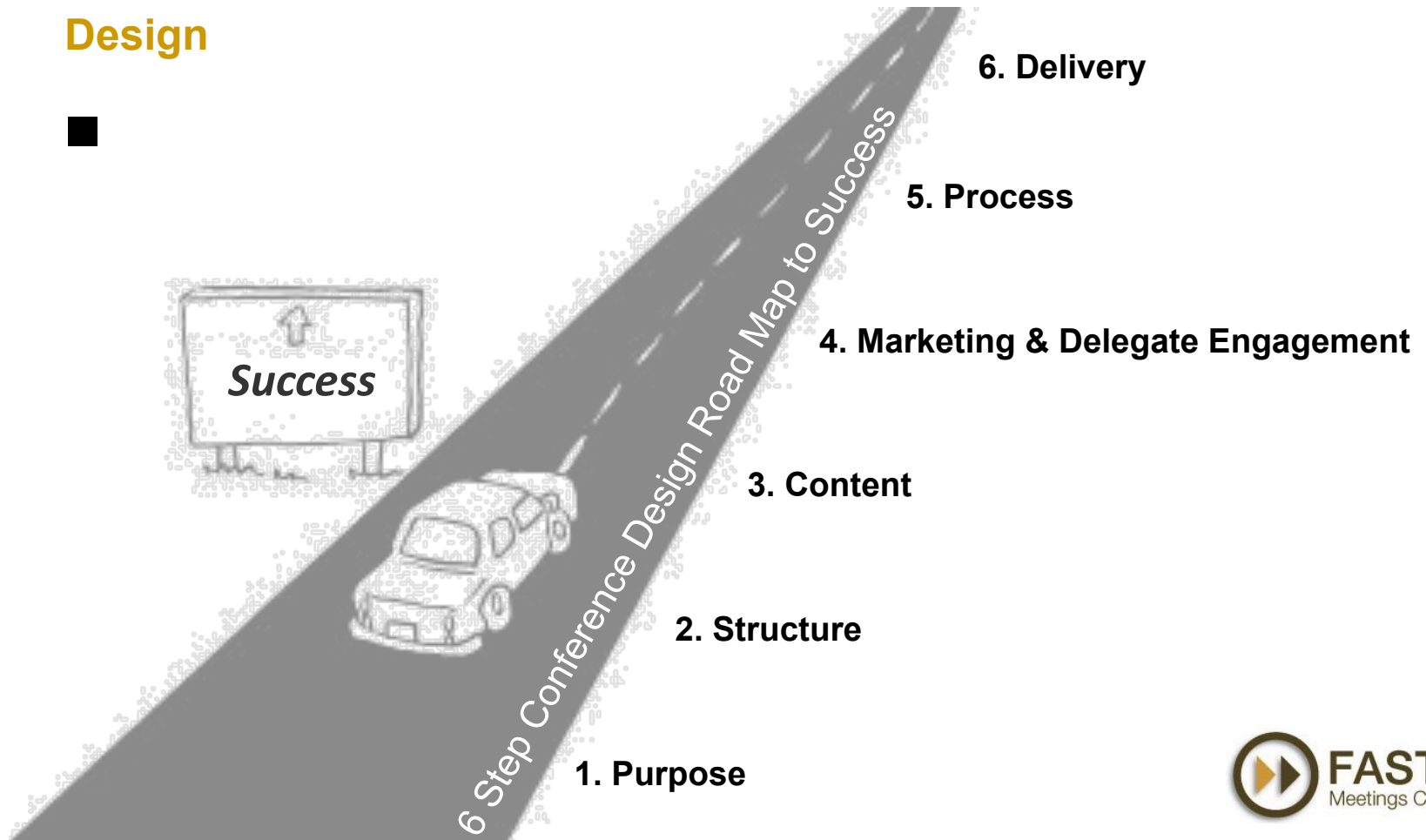

# Our Services

## 2. **Coach** Client Facilitators and Presenters

From This



To This!



# Our Services

## 3. Facilitate and MC



# FAST Meetings Co.

Established in 1997

Service Australia wide

Experts in facilitation, consulting, innovation and sustainability

Our core products:

**Business Meetings:**

Meeting Effectiveness Coaching and Training

**Conference Impact:**

Conference Design and Facilitation

**Strategy Development:**

Strategic Planning Design and Facilitation



# Contact Us today

Onur Ekinci  
Business Facilitator  
[onur.ekinci@fastmeetings.com.au](mailto:onur.ekinci@fastmeetings.com.au)

David Pointon  
Managing Director  
[david.pointon@fastmeetings.com.au](mailto:david.pointon@fastmeetings.com.au)

Call us: 61 2 9502 2022

*“From the initial planning right through to the facilitation of the 2009 ACEA National Conference, the FAST Meetings team approached our event with **absolute professionalism**. Their vast conference experience gave us the confidence that we were heading in the right direction with our content and speakers. Their in-depth knowledge and hands-on approach helped us to deliver our first conference in 15 years and make it a huge success. We look forward to working with FAST Meetings again as we plan our 2010 conference.”*

**Megan Motto – CEO – Consult Australia (formerly ACEA)**

